

- NOTES:
- 1.CCW
 - 2.Front bearing: NTN6006 LLUC3/5K (Made in Japan)
 - 3.Product to be shipped in plain white box, styrofoam packaging
Include Dyno Plot in box.
 - 4.Box to be marked:
Part Number: ME1003
Made in China

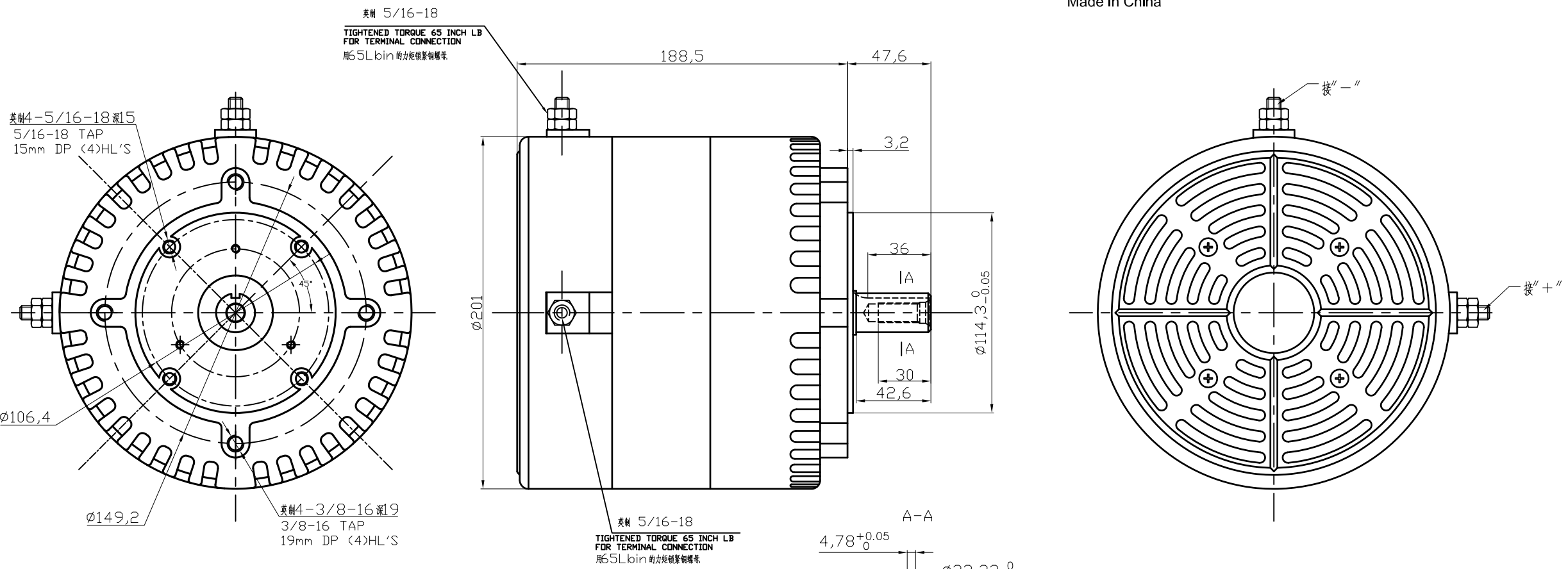

NAMECARD DATA
 PART # ME1003
 DATE CODE XXXXXX
 SERIAL #:XX.XX.XXXX
 Mars Electric LLC
 Milwaukee, WI USA

规格表

型号 MODEL	输出功率 (W) POWER (W)	电 压 (V.DC) VOLTAGE (V.DC)	转 矩 (LB-IN) TORQUE (LB-IN)	额定转速 (RPM) LOADED SPEED (RPM)	空载转速 (RPM) NO LOAD SPEED (RPM)	电 流 (A) CURRENT (A)
ME1003	11500	72	315	2800 ± 250	appr. 3700	± 200

REV.	CHANGES	BY	ECO NO.	DATE	DO NOT SCALE DRAWING THIS DRAWING IS PROPRIETARY PROPERTY OF MARS ELECTRIC LLC CORPORATION DISCLOSED IN CONFIDENCE WHICH MAY NOT BE USED OR DISCLOSED WITHOUT PERMISSION. RETURN PROMPTLY AFTER USE.	DIMENSIONING AND TOLERANCING PER ANSI Y14.5M-1994	MATERIAL	TITLE	Mars Electric LLC MILWAUKEE, WISCONSIN, U.S.A.
-	-	-	-	-	-	CLASSIFICATION OF CHARACTERISTICS		OUTLINE	
-	-	-	-	-	-	CRITICAL (C):	S/N: CODE:	DRAWN: lxp 10.04.23	DESIGN VENDOR: -
-	-	-	-	-	-	EMMISSIONS (E):	MODEL NO:	APPR:	
-	-	-	-	-	-	MAJOR (M):	SIM TO:	DEPT:	
-	-	-	-	-	-			SCALE: -	0JW.T. 301.354